



HOPPECKE
POWER FROM INNOVATION

Product catalogue

Standard components for charging stations

Preamble

The prices listed here are Intercompany prices ex works. **The shipping costs and the necessary fastening material are not included in the product prices.** These can be requested individually for the various standard components from HOPPECKE's back office. After a technically and commercially clear order, the average delivery time is about 3-4 weeks. Depending on the destination and due to unexpected events, the maximum delivery time may differ from the standard.

All products and associated options are delivered separately, so they are not pre-assembled.

The illustrations and diagrams shown may differ from the actual products. In addition, errors can occur in this catalog despite careful processing / checking. If you have any doubts, please contact the internal sales team.

Table of content

1.	Battery trolley – BT	1
1.1	Short description.....	1
1.2	Examples.....	1
2.	Mobile roller bed – MRB	2
2.1	Short description.....	2
2.2	Examples.....	2
3.	Standard roller bed with side frames – SRB-S	3
3.1	Short description.....	3
3.2	Examples.....	3
4.	Battery stands – BS	4
4.1	Short description.....	4
4.2	Examples.....	4
5.	Charger shelf – CS	5
5.1	Short description.....	5
5.2	Examples.....	5
6.	Safety equipment and signs	6
6.1	Short description safety equipment.....	6
6.2	Examples and scope of delivery	6
6.3	Short description safety signs	7
6.4	Examples.....	7
7.	Water treatment systems	8
7.1	Short description.....	8
7.2	Examples.....	8
8.	Contact addresses	9
8.1	General.....	9
8.2	Order process.....	9

- 9. Products for turnkey solutions-trak| systemizer fleet 11**
- 9.1 Battery changing units – trak | Xchange.....14
- 9.1.1 Battery changing unit for small batteries15
- 9.1.2 Battery changing unit for medium to large batteries16
- 9.2 Battery monitoring and management systems17
- 9.2.1 Battery monitoring – trak | monitor easypick.....17
- 9.2.2 Battery management – trak | monitor18
- 9.3 Bus bars19
- 9.4 Ventilation systems.....20
- 10. Mobile charging station – trak | systemizer powercube 21**
- 10.1 Variants and technical dimensions.....22
- 10.2 Examples.....22
- 11. Notes 23**

1. Battery trolley – BT

1.1 Short description

The battery trolley is a freely movable, hand-guided trolley for roller-mounted batteries with side change. It is generally used for trucks with small and light 24V batteries.

- Working load: Max. 375kg/ battery
- Changing height BT without height adjustment: 130mm
- ⚠ BT with fixed height cannot be used with every truck type (e.g. small battery room inside truck)
- Changing height BT-PT with height adjustment (~110mm): Min. 135mm
- Painting: RAL 9005 (black)
- 4 heavy-duty rollers for moving (2 fixed, 2 tilting)
- PT- hand pallet truck can be ordered separately
- ✍ Changing height must be specified when ordering

Individual changing heights should be requested from the HOPPECKE sales office.

1.2 Examples



Trolley (fixed)
BT-850-350-1



Trolley (height adjustment)
BT-PT- 850-350-1

2. Mobile roller bed – MRB

2.1 Short description

The mobile roller bed is universally applicable because it can be gradually adapted to different battery widths. It can be moved freely with a standard pallet truck provided by the customer. A battery stopper with an adjustable screw is integrated for safe movement of the battery.

- Working load: Max. 1000kg
- Changing height: Min. 110mm
- 2 lengths available: 1.) 850mm and 2.) 1250mm
- Height of standard side frames: Ca. 100mm
- Adjustment range side frames: 180 – 580mm
- Painting: RAL 9005 (black)
- ✎ Battery dimensions must be specified when ordering
- Option: Higher side frames 500mm (nonadjustable – fitted to the battery dimensions)

2.2 Examples

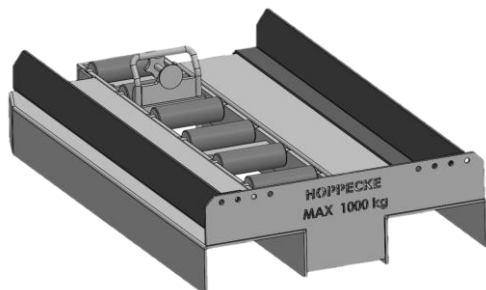

Mobile roller bed
MRB-850/1250-590

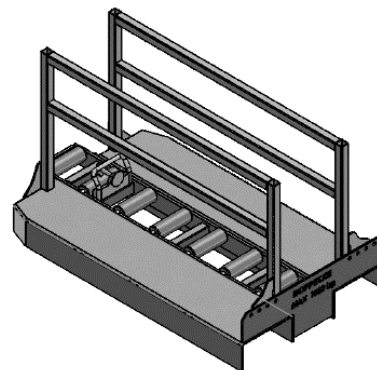

Higher side frames for
MRB-850/ 1250-590

3. Standard roller bed with side frames – SRB-S

3.1 Short description

Standard roller beds are used for batteries with side change. They have fixed outer dimensions and stable side frames to prevent the batteries from tipping. There is a battery stop on the front of the roller beds, too.

- Changing height: Min. 125/ max. 350mm
- ✂ Changing height must be specified when ordering
- Feet adjustment range: ± 25 mm (wrench size 32mm)
- Height of side frames: 560mm (floor – top)
- Painting: RAL 9005 (black)
- FFP – floor fixing plates (2x per SRB-S – included in delivery)
- ⚠ When installing, the opening of the „FFP“ faces inwards
- Option: CS – charger shelf: Height 1600mm (floor – shelf), depth 450mm
- Option: „L-Bar“ for centering pallet truck (max. width 620mm) under SRB-S single/double

3.2 Examples



SRB-S: Standard roller bed with side frames – single/ double/ triple

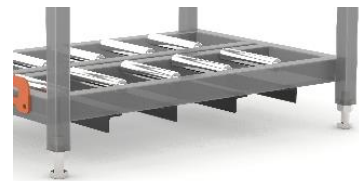

L-Bar: Angles for centering pallet trucks



SRB-S + CS: SRB-S with charger shelf (CS) – single/ double/ triple



PPH-450/650: Plug plate holder for standard roller beds



PP-Bar: Plug plate & bar for charger shelf (CS)

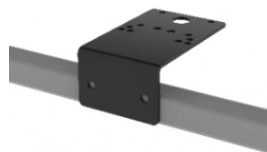

PP-CS: Plug plate for charger shelf (CS)



FS-500- 2000: fork stopper

4. Battery stands – BS

4.1 Short description

The battery stands can be ordered in different versions, depending on the type of battery change. BS-R and BS-OF can be used for batteries with side change. BS-R can be individually assembled in width, BS-OF are customized to the battery dimensions. Both have an open front for placing the battery using a pallet truck. When changing with a crane or lifting gear the BS-GR with grid can be used.

- Painting: RAL 9005 (black)
- BS-OF are customized in width and length
 - Rack width = battery width + 50mm
 - Rack depth = battery length + 50mm
- ✍ Changing height, dimensions of the battery and the pallet truck must be specified when ordering
- ⚠ Change vehicle must not be too wide so that it can enter the open front.
- Height BS-GR: 150mm
- Changing height BS-OF/ BS-R: ~110mm
- Mounting on the floor using foot plates and impact anchors
- Option: Mounting kit can be ordered for an additional charge

4.2 Examples



BS-R: Battery stand rail - pair

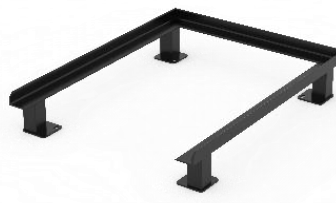

BS-OF: Battery stand with open front

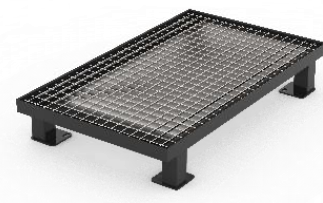

BS-GR: Grid battery stand

5. Charger shelf – CS

5.1 Short description

The charger shelf is suitable for storage of all common chargers. A plug plate rail “PP-Bar” for fixing the plug plate “PP-CS” (option) is located in front of the shelf and is included in the delivery of the charger shelf.

- Characteristics shelf: Height 1600mm, depth 650mm, RAL 9005 (black)
- Mounting on the floor ground using foot plates (Ø12mm)
- Option: PP-CS – plug plates for fixing the charger plugs (must be ordered separately)
- Option: Mounting kit can be ordered for an additional charge

5.2 Examples



CS: Charger shelf with PP-Bar – plug plate bar



PPB-WM: Plug plate bracket wall mounted



CS-FM: Charger shelf – floor mounted (free positioning)

6. Safety equipment and signs

6.1 Short description safety equipment

For safe handling of batteries, we offer a safety package to provide employees with comprehensive personal protection and first-aid equipment. Depending on the size and quality, battery charging stations require safety equipment according to DIN-EN 62485-3, BG and VDS.

The shown safety equipment is only an example and must be delivered from the local subsidiary.

6.2 Examples and scope of delivery



Safety package I

Scope of supply

- 1x safety gloves Latex, size 10
- 1x single-pane safety glasses, clear
- 1x first aid kit for companies DIN13157
- 1x apron Gunova, black
- 1x first aid cabinet
- 1x mandatory sign „protective glasses“ SK-film
- 1x mandatory sign "gloves" SK-film 100mm
- 1x mandatory sign "apron" SK-film 100mm



Safety package III

Scope of supply

- Safety package II +
- 1x combi-shower incl. sign
(stationary body shower+ stationary eye wash)



Safety package II

Scope of supply

- Safety package I +
- 1x eye wash, pH neutral
- 1x eye wash, NaCl
- 1x wall cabinet with integrated mirror
- 1x eye emergency protocol
- 1x plastic safety sign “Eye wash kit”



Binding agent kit

Scope of supply

- 1x 40l binding agent
- 1x wide neck watertight vessel labelled
“Binding agent”
- 1x shovel

6.3 Short description safety signs

Depending on the size and condition, battery charging stations must be labeled with various warning and information signs in accordance with DIN-EN 62485-3, BG and VDS regulations. A selection of signs is listed below.

6.4 Examples

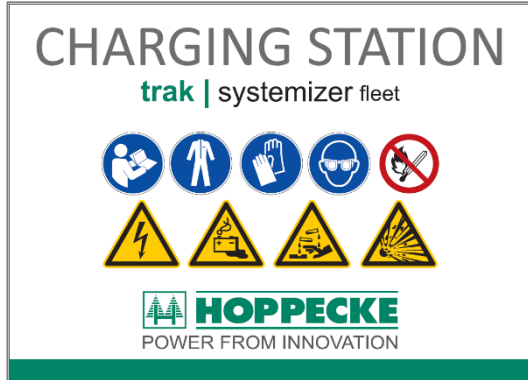

Information board „charging station“
single sign 900x650mm AluDibond

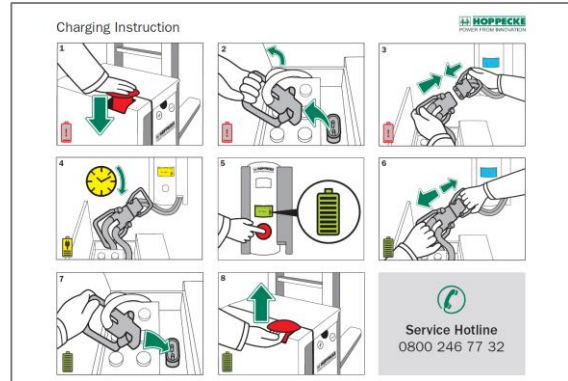

Information board „charging instructions“
as comic 420x297mm AluDibond

7. Water treatment systems

7.1 Short description

Regular water refilling increases the life and performance of a battery. Water treatment is therefore an economic must if batteries are serviced in large numbers. All our systems meet the water quality requirements of the ZVEI Batteries Association.

From the smallest to the largest water treatment system - all systems are working in accordance to the proven principle of the ion exchanger via a mixed bed with special resins.

Advantages:

- Economical, thanks to special water flow for 100% utilization of the capacity
- Safe, thanks to consistently good water quality without losses due to storage
- Environmentally friendly, thanks to the long service life of the resins and the almost unlimited regenerability

- Types: Analog conductivity meter
 Digital conductivity meter with color display and visual signal

The water station DS battery Plus is a compact water treatment system for holding a stainless-steel ion exchanger and for the ideal production of refill water for batteries. Furthermore, the water station can optionally be delivered with a hose reel.

7.2 Examples



Water treatment systems



DS water station

8. Contact addresses

8.1 General

HOPPECKE Batterien GmbH & Co. KG

Bontkirchener Str.1

D-059929 Brilon

Tel: +49 (0) 2963 61-0

Fax: +49 (0) 2963 61-449

E-Mail: motivepower@hoppecke.com

8.2 Order process

In order to ensure a smooth ordering and delivery process, the following basic information must be provided for every order.

The scope of information includes a completed order sheet with:

- HOPPECKE material number
- Battery type / dimensions (alternatively the HOPPECKE tray number)
- Truck manufacturer and type
- Truck changing height
- Color (if the color is not specified, RAL9005 is automatically selected)
- Delivery address and details from contact person
- Customer order number

Send your detailed inquiries and the completed order formular to the **system sales back office**. They will forward this to the responsible colleagues.

9. Products for turnkey solutions-trak| systemizer fleet



HOPPECKE
POWER FROM INNOVATION







trak | systemizer fleet

Cost-optimised charging stations
for motive power batteries

www.hoppecke.com

More efficiency thanks to innovative components
trak | systemizer fleet – perfectly coordinated

Modern intralogistics places increasing demands on every single component within the process chain – including the battery changing station. Accelerated processes ensure the highest possible efficiency in value-adding activities. This is achieved by solutions optimally tailored to your requirements.

100% turnkey, including all prescribed safety instructions and first aid station
trak | systemizer fleet

50% Up to 50 % more space with customised system racks
trak | Xcharge

50% Up to 50 % energy savings thanks to optimised charging with
trak | monitor 4.0

25% Up to 25 % fewer charge interruptions
trak | charger HF premium

85% Up to 85 % savings in operating costs due to minimised water consumption and maintenance intervals
trak | uplift iq

35% Up to 35 % less investment by reducing the number of batteries and maximum space saving
trak | Xchange tu

50% Up to 50 % time saved with minimum effort battery changing
trak | Xchange PU

40% Up to 40 % faster safe battery change (up to 1.8t)
trak | Xchange MU

Made in Germany

HOPPECKE charging stations – flexible and tailored to your requirements.

We always develop your individual solution for turnkey central charging and changing stations, outdoor solutions or battery charging stations.

The holistic planning takes into account the room dimensions, shift and break models, goods movements, vehicle types as well as ventilation, floor coating and the type of battery change. Thanks to the modularity and flexibility of our system components, we also help you to reduce your investment and energy costs and, in addition, to optimize your fleet.

Trust in our expertise and many years of experience in consulting, planning and realization of charging stations.

Your benefit with HOPPECKE:

- On-site analysis and advice
- Constructional planning of your charging station including compliance with legal requirements
- Layout planning
- Delivery of all system installations and accessories
- All trades from a single source: Ventilation, busbar, coating, etc.
- Installation, maintenance, inspection and training on site
- Commissioning and acceptance of the charging station

More than the sum of its parts – trak | systemizer fleet - the customisable charging station



The number of electric forklifts in intralogistics is growing consistently. Currently, about one in five forklifts worldwide is running on batteries. In Europe, the share of electric forklifts has increased from 49 % to 55.2 % in the past five years.

For the efficient and smooth operation of a modern forklift fleet, the use of battery charging and changing stations is indispensable – especially in a 24/7 multi-shift operation.

 Analysis	 Expertise	 Solutions
<p>We analyse your energy requirements and local conditions directly on site</p> <ul style="list-style-type: none"> ▶ Vehicle fleet ▶ Energy consumption ▶ Logistics routes ▶ Shift / break models ▶ Measurements ▶ Floor conditions ▶ Electric installation ▶ Ventilation 	<p>Our many years of experience guarantee innovative solutions tailored to your requirements.</p> <ul style="list-style-type: none"> ▶ Concept development for central and decentralised charging stations and sites ▶ Technical drawings ▶ Consulting on safety requirements ▶ Support for tenders ▶ European market leader in research and development 	<p>We plan your system holistically, sustainable and modular using state-of-the-art technology.</p> <ul style="list-style-type: none"> ▶ Extensive competence in energy storage ▶ Company-specific solutions in accordance with European standards ▶ Optimisation of logistics routes, energy saving and space utilisation ▶ Support for the architect and/or the planner

Apart from economic efficiency and operational safety, easy handling plays an important role. The driver must be able to handle the battery exchange easily, quickly and intuitively.

With the trak | systemizer fleet, HOPPECKE offers a system solution tailored to your requirements. Perfectly matched components guarantee the highest possible level of efficiency. Only in combination can the individual parts reach their full potential.







 Components	 Turnkey	 Service
<p>We only use high-quality and perfectly coordinated HOPPECKE components.</p> <ul style="list-style-type: none"> ▶ Modular and flexible ▶ Delivery of all system assemblies and accessories ▶ All from one source: ventilation systems, electrical installations, floor coatings etc. ▶ Flexible energy billing solutions ▶ Top quality - Made in Germany 	<p>HOPPECKE system solutions are ready to use. No subsequent installation necessary.</p> <ul style="list-style-type: none"> ▶ Project management or support for sub- or complete projects ▶ Installation of turnkey charging stations ▶ Commissioning and acceptance of charging stations ▶ Operation of charging stations ▶ Energy Management 	<p>Our extensive range of services secures your investment in the long run and ensures optimal availability.</p> <ul style="list-style-type: none"> ▶ On-site installation, maintenance, inspection and training ▶ Global collection and waste management system ▶ Professional consulting based on the accumulated data ▶ Identification of optimisation and savings potentials ▶ Individual models for purchase, rental and refurbishment

9.1 Battery changing units – trak | Xchange

Depending on the dimensions and weight of the battery and the changing method, HOPPECKE has big range of different changing units. All variants are specially tailored to customer needs and thus reduce the time and cost involved in changing the batteries.

When designing a system, the number of batteries required for operation is considered as well as their size and the type of truck in which they are used.

Overview changing units

Small batteries 12V - 48V		Medium batteries 24V - 80V		Medium – large batteries	
<ul style="list-style-type: none"> Fleet size: < 20 batteries Battery weight: < 650 kg TU – transfer unit by hand Movable on guide rails 		<ul style="list-style-type: none"> Fleet size: < 20 batteries Battery weight: < 2500 kg MU – Manual unit with gearbox PU – Powered unit with hydraulic/ magnet Free movable 		<ul style="list-style-type: none"> Fleet size: < 20-300 batteries Battery weight: < 2500 kg PU – Powered unit with hydraulic/ magnet Free movable FU – fully automatic drive & change unit 	
TU	TU-HA	MU	PU	PU	FU
					

Your benefits:

- Low effort
- Fast and save battery changing
- Little need of space
- Modular expandability of the charging station
- Choice between manual or driven changing units

9.1.1 Battery changing unit for small batteries

The HOPPECKE battery changing units trak | Xchange TU are suitable for smaller batteries and were specially developed for electric pallet trucks and low-level order pickers with rollers and side change of the batteries. They are equipped with a double roller bed, which enables a quick battery change.

All trak | Xchange TU systems run on floor-mounted rails to guarantee easy movement. At the same time, the safe transport of the battery is ensured by a locking device.

The variant trak | Xchange TU-PT is equipped with a special lifting mechanism that enables a height adjustment of 130mm.

Your benefits:

- Manual changing unit for 12V - 48V batteries
- Space saving because of 2 compartments on the changing unit
- Easy movable on guide rails
- Modular to allow flexible expansion
- Simple, robust design enables changing times of approx. 2 minutes

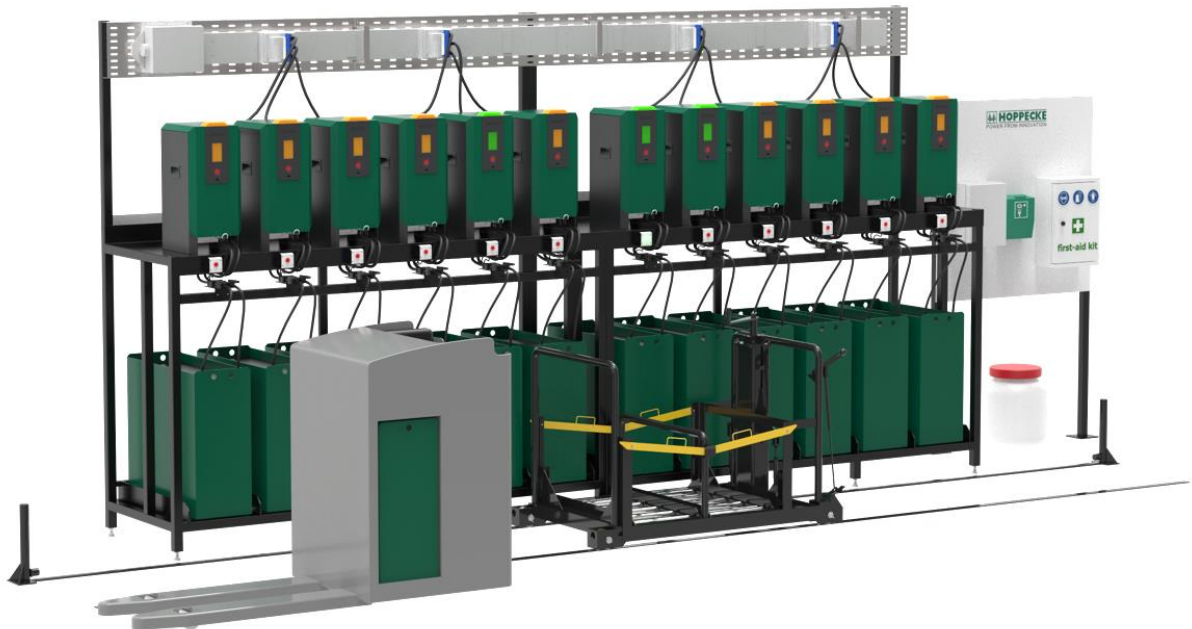

9.1.2 Battery changing unit for medium to large batteries

The trak | Xchange MU is equipped with a roller conveyor. This battery changing unit has a manual gear-assisted device to facilitate the insertion and removal of the battery into the vehicle and to reload it onto the roller beds.

On the trak | Xchange PU, the exchange attachments are equipped with a hydraulically driven extension and a corresponding electromagnet. They have a hydraulic device for easy insertion and removal of the battery into the vehicle and onto the roller beds.

The trak | Xchange MU and PU systems can be moved freely and allow a quick battery change. At the same time, the safe transport of the battery is ensured by a locking device.

Your benefits:

- Changing unit for 48V - 80V batteries
- Little effort due to gearbox support or no physical effort due to driven changing device
- Flexible use with different changing heights
- Safe and easy usability
- High security when moving the battery through locking device



9.2 Battery monitoring and management systems

9.2.1 Battery monitoring – trak | monitor easypick

Trak | monitor easypick is an easy monitoring system for small up to medium charging stations. A green signal lamp indicates the battery which can be removed next.

Your benefits:

- Management of up to 48 chargers
- Equally use of the batterie pool
- Observance of cooling times of the batteries

Without trak | monitor easypick

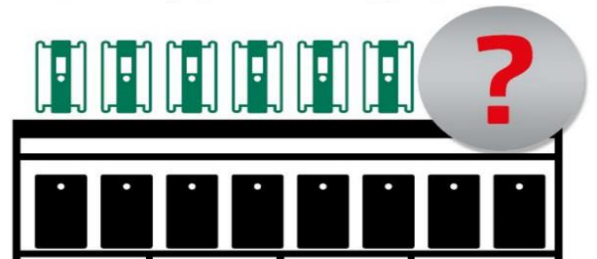

With trak | monitor easypick



Each charging place/ charger requires one LED housing. The HOPPECKE chargers must be equipped with an option board and a potential-free contact. If you place a new order the option “easy pick system” must be selected.

Price and individual planning on request. The systems sales are available to provide any advice.

9.2.2 Battery management – trak | monitor

With trak | monitor, our management system for charging stations, batteries and chargers, you have all performance and consumption data at a glance at all times: The System communicates with the chargers and with the HOPPECKE battery controllers. This provides for highest possible transparency so you can make real-time data decisions.



Your benefits:

- Personalized dashboards for clear evaluation - also available from mobile devices - and sending alarm messages
- Expandable at any time - from battery monitoring to peak shaving
- Central provision of the collected data of the chargers and batteries of the entire operation for evaluation in clear reports
- Management of up to 10 battery pools and 200 chargers
- Uniform use of the battery pool and adherence to the cooling times
- Reduction of time and cost for battery maintenance and service
- And much more



Price and individual planning on request. The systems sales are available to provide any advice.

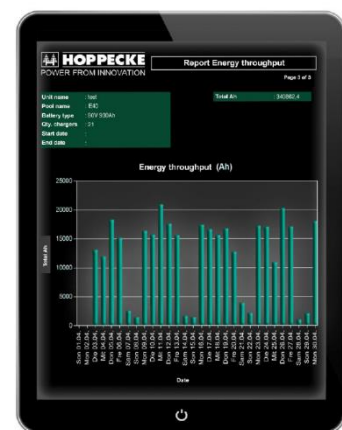

9.3 Bus bars

Our bus bars are a flexible and economical energy distribution system with a wide range of optional accessories for safe, simple and fast expansion of installations.

Your benefits:

- Compliance with degrees of protection IP52 - IP55
- Low fire load of 1.32 kWh/m
- Excellent short-circuit resistance
- No customer-specific electrical installation of individual sockets required

Thanks to the busbar, the charging / changing station is easier to integrate into the house electrical system and even flexible when moving to a different hall later. Only one main voltage cable must be connected to the infeed box (interface between customer and HOPPECKE).

The tap-off boxes are equipped with mains sockets (Schuko or CEE) for chargers and with screw-type fuses, the types and numbers are order-related. They can be individually equipped with adapted fuses (fuse / FI / FI DC sensitive). RCDs / disconnectors are not included in the standard planning according to DIN EN 62485-3. If they are required, they must be specifically requested.

Examples



9.4 Ventilation systems

In the case of batteries with aqueous electrolyte, gases are released during charging. They develop through electrolysis of the water by the charge current. The gases produced are oxygen and hydrogen. If released to the atmosphere, an explosive mixture can result as soon as the proportion of hydrogen in the air exceeds 4%.

When the charger is switched off, the gas escapes noticeably after an hour. However even after this time, safety precautions are needed because gases which have been held within the cell can escape suddenly, e.g. by moving the battery when fitting in the vehicle or by the movement of the operating vehicle.

A battery system is not considered to be at risk of explosion if batteries are housed in it in such a way that the gas mixture generated during charging and discharging is diluted in the surrounding space so that it will certainly lose its explosiveness.

However, in proximity (according to EN62485-3 less than 0.5 m) of the gas outlets, dilution cannot always be guaranteed.

If a ventilation system is to be planned by HOPPECKE, it is recommended that the shelves have a housing so that the entire battery is enclosed. If the batteries are completely enclosed the gases can be optimally extracted.

Examples



10. Mobile charging station – trak | systemizer powercube

The trak | systemizer powercube is a turnkey solution for charging and changing of batteries in the field of industrial trucks. The charging container is a complete mobile charging station with integrated ventilation system and lighting as well as sophisticated technology down to the smallest detail.

It can be set up variably outside the factory premises, but also at any location within the production that has a suitable power connection.

The energy supply of your vehicle fleet is thus ensured both centrally and decentrally at all times. With the trak | systemizer powercube you create space and ensure greater flexibility, for example during order peaks with high capacity utilization.



Your benefits:

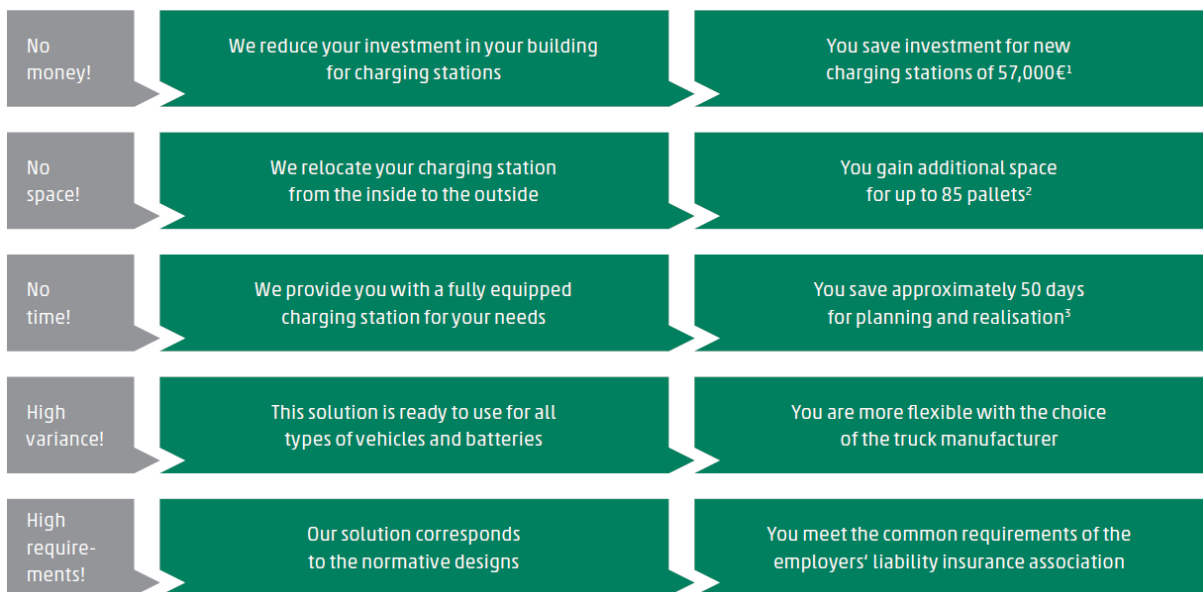

10.1 Varaint and technical dimensions

Typ	24V batteries (835x223x784)	48V batteries (835x634x784)	80V batteries (1028x999x784)	Outer dimensions WxDxH	Inner dimensions WxDxH	Net weight
TS-PC-3R/L	16	6	4	5800 x1625 x2980	2x 2550 X1280 X2380	3t
TS-PC-5R/L	24	10	6	8600 x1625 x2980	2x 3850 X1280 X2380	4,1t

10.2 Examples



